

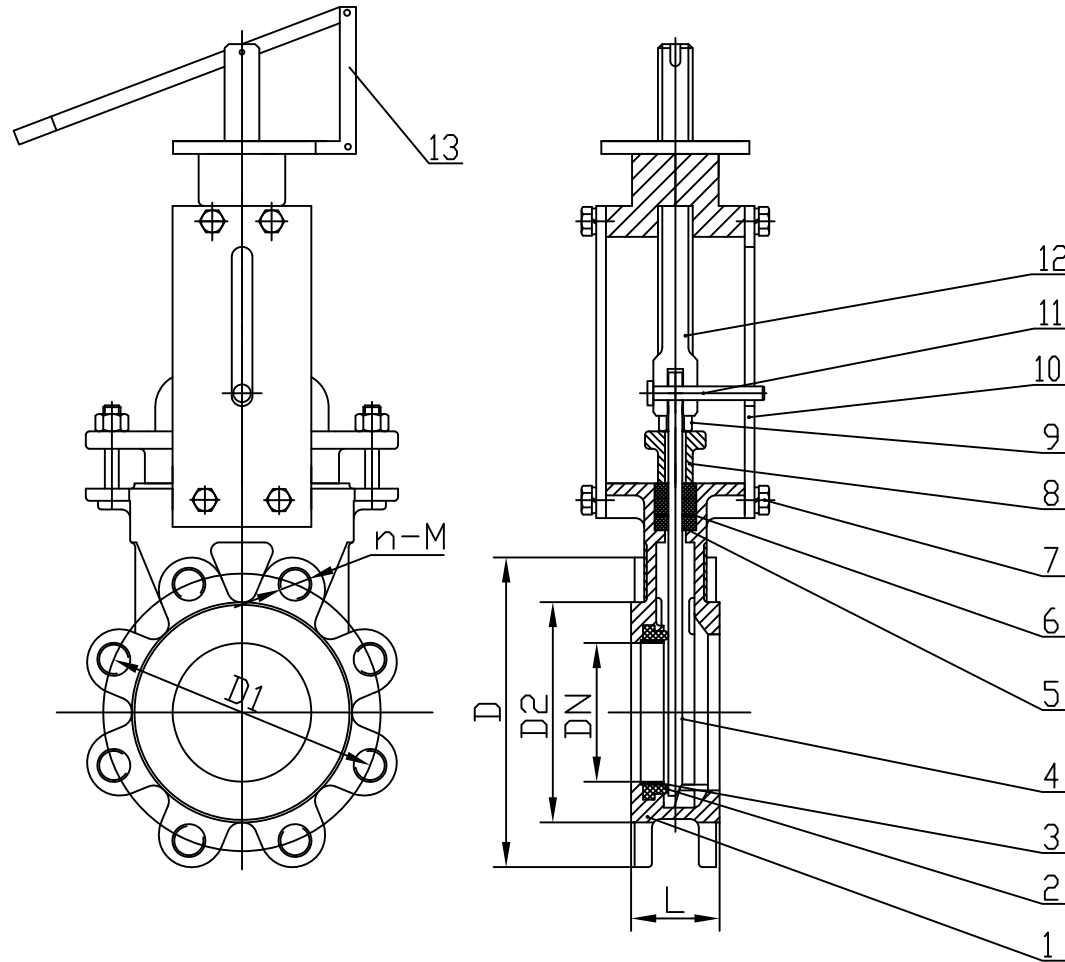

Size	Main Dimension (mm)PN10				
	DN	D	D1	D2	n-M
100	215	178	154	8-M16	51



Technical Requirements

1. Design & manufacture conform to MSS SP-81
2. Face-to-Face conforms to MSS SP-81
3. Flange dimensions conform to AS2129-Table E
4. Test & Inspect conform to MSS SP-81

13	Mechanical Quick Lever	SS304	
12	Stem	A276 316	
11	Pin	Stainless Steel	
10	Yoke	Carbon Steel	
9	Gland Bolt	A193 B8	
8	Gland	A351 CF8M	
7	Yoke Bolt	Stainless Steel	
6	Gasket	EPDM	
5	Packing	Graphite	
4	Knife	SS316	
3	Retainer Ring	SS316	
2	Seat Ring	EPDM	
1	Body	A351 CF8M	
NO	PART NAME	MATERIAL	REMARKS

SPECIFICATIONS				DESIGNED BY					
Nominal pressure		PN10		CHECKED BY				DRAWING NO	
Testing Pressure	Shell Test	1.5	MPa	STANDARDIZED BY		PZ73X-PN10		0	
	Closure Test	0.28		APPROVED BY		THE USER CONFIRM		Knife Gate Valve	
	Back seat Test			DATE		2016-03-08			
	Air Test	/							
Temperature		-29~80°C							
Applicable Media		Water,Oil,Steam							