

PN	DN	D	D1	D2	L	b	f	Z-d
16	ø50	ø150	ø114	ø102	200	18	3	4-ø18
	ø65	ø165	ø127	ø122	220	18	3	4-ø18
	ø80	ø185	ø146	ø138	245	20	3	4 ø18
	ø100	ø215	ø178	ø158	290	20	3	8-ø18
	ø125	ø255	ø210	ø188	330	22	3	8-ø18
	ø150	ø280	ø235	ø212	356	22	3	8-ø22
	ø200	ø335	ø292	ø268	495	24	3	8-ø22
	ø250	ø405	ø355	ø320	595	26	3	12ø22
	ø300	ø455	ø406	ø378	695	28	4	12ø26

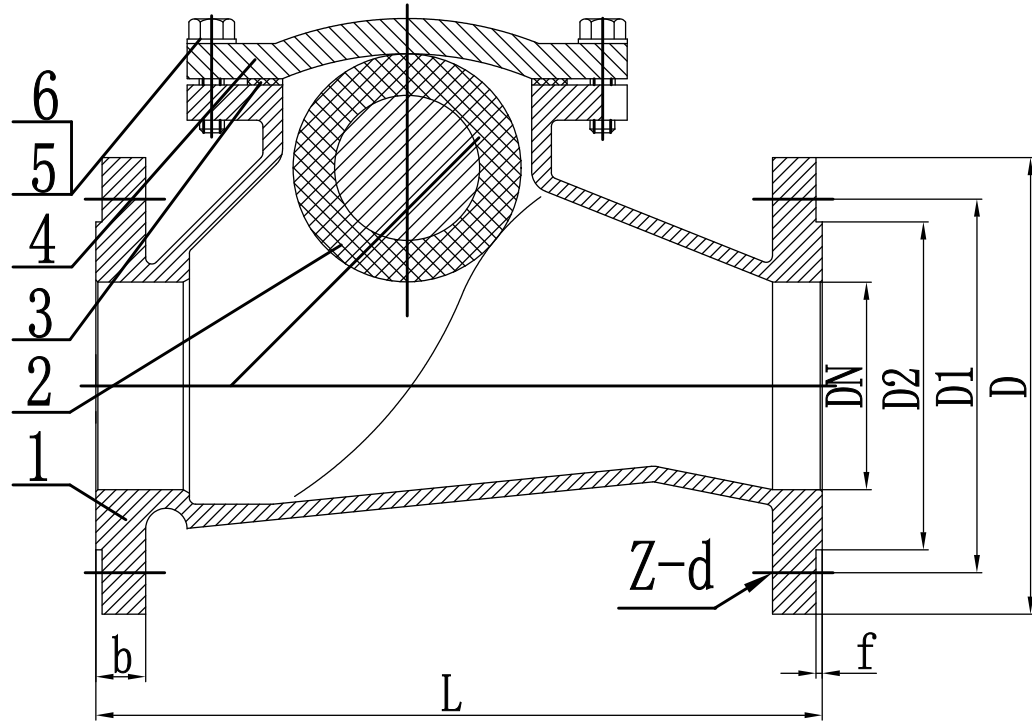

Performance Specification		
PN	1.6 MPa	
Strength Test	2.4	MPa
Sealing Test		
Air Test	0.6	
Temperature	≤200	° C
Medium	Water , Gas , Oil	

Technical Date
1. Flange standard :Table E AS2129

NO	PART NAME	MATERIAL	REMARK
1	BODY	CF8M	SS316
2	BALL FLOAT	Viton/STEEL	
3	GASKET	Viton	
4	BONNET	CF8M	SS316
5	BOLT	SS316	
6	WASHER	SS	



mark / Doc				Sign		Date		Assembly		Ball Check Valve
Design		Standard		sample mark		Weight		Scale		
Admit		Date		Total Page		Page				
Craft		Date		Total Page		Page				